

OIL MIST ELIMINATORS



Oil Mist Separation



7/24
HOT LINE
+90 530 280 90 36

OIL MIST ELIMINATORS

AREAS OF USE

- ▶ Applications which require oil-less air
- ▶ Oil mist separators which are located after oil compressors, vacuum pumps and fan blowers
- ▶ Systems which require high air flow but low pressure drop
- ▶ Vacuum freezing applications
- ▶ Processes where gas is taken out by vacuum
- ▶ Vacuum coating applications
- ▶ Food processing plants
- ▶ Nailing / stapling machines
- ▶ Industrial vacuum applications
- ▶ Cement and paper plants

DESIGN

Oil mist eliminators are designed for these requirements

- ▶ Separation of oil mist from piston or screw compressors
- ▶ Long service time and resistance against hard working conditions
- ▶ Protection of the system against oil mist in case compressor oil separator is malfunctioning

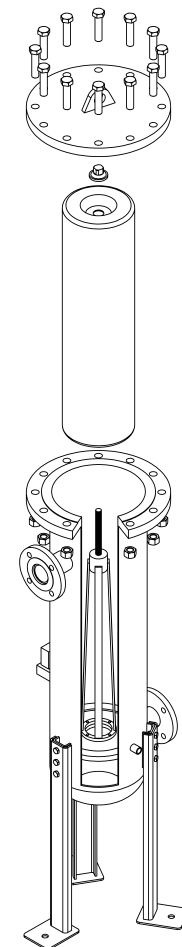

PROPERTIES

- ▶ Low pressure drop
- ▶ High oil retention capacity
- ▶ Easy cleaning and maintenance
- ▶ Full impermeability with O-rings
- ▶ Automatic drainage
- ▶ Alternative drainage types
- ▶ Maximum operating pressures 14 Bar (g)
- ▶ Wide temperature range (min 4°C (40°F), max 80°C (176°F))
- ▶ Grounded elements to prevent static
- ▶ Particle retention up to 0,01 micron and decrease of oil content down to 10 ppm
- ▶ Slow and effective separation at specified flowrates by enlarged surface area and therefore elimination of oil mist.



OIL MIST SEPARATOR ELEMENT

- ▶ Long service life
- ▶ Energy savings due to very low pressure drop
- ▶ Pressure difference for filter change 2.5 psig (170 mbar)
- ▶ Thorough separation of air and oil
- ▶ High quality seals for efficient filter operation



TECHNICAL PROPERTIES

▶ SAMPLE AIR LINE FOR OIL-FREE COMPRESSORS

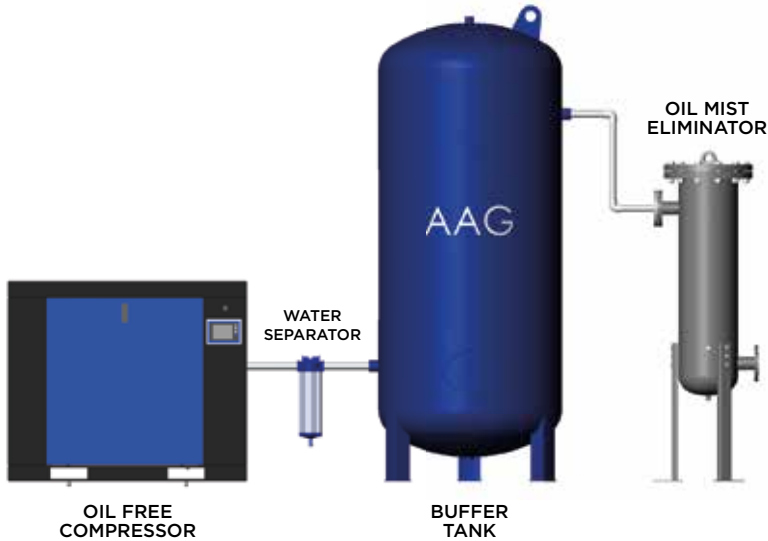

▶ DEW POINT

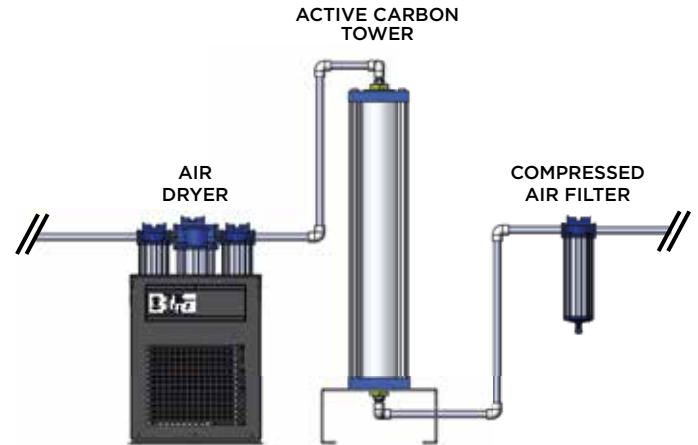

▶ DEW POINT

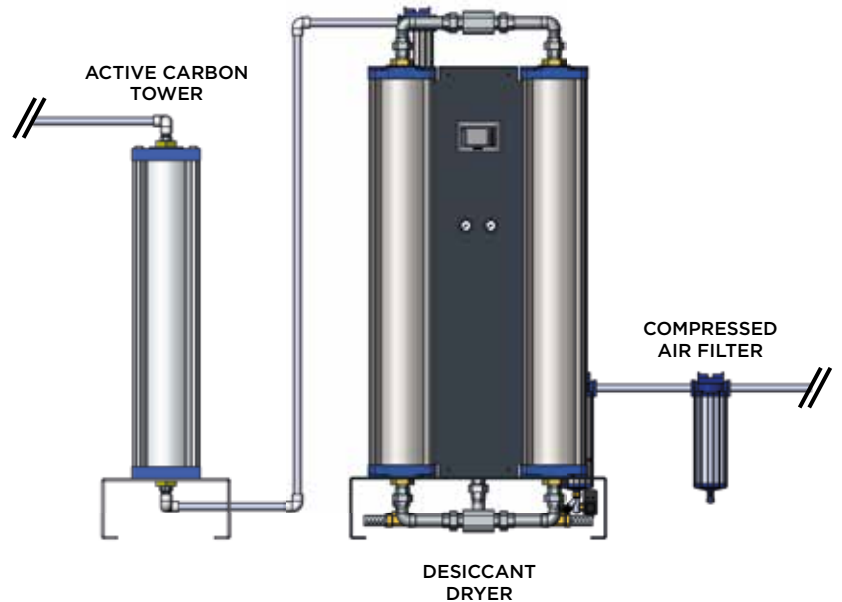
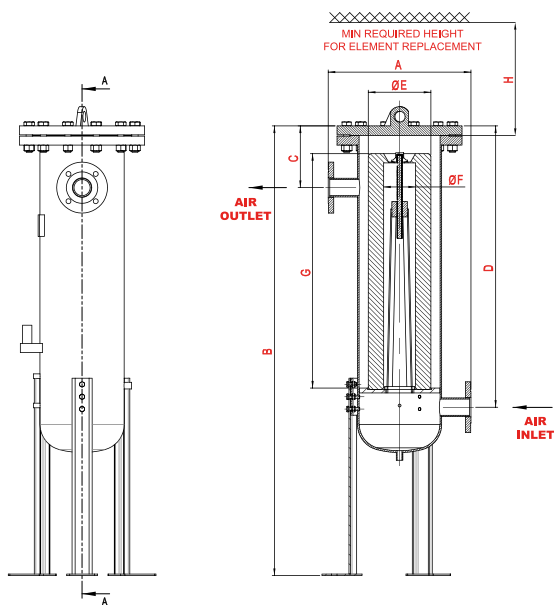

OIL MIST ELIMINATORS TECHNICAL PROPERTIES

Model	Drainage Connection Size	Inlet Connection Size	Flowrate		Max Operating Pressure	Dimensions							
			(m³/h)	cfm		A	B	C	D	ØE	ØF	G	H
OVE - 4250	1/2"	DN50	255	150	14 Bar	500	1003	209	459	203	103	305	330
OVE - 8500	1/2"	DN50	510	300	14 Bar	500	1105	209	559	203	103	407	435
OVE - 17000	1/2"	DN50	1020	600	14 Bar	500	1461	209	916	203	103	762	790
OVE - 22500	1/2"	DN80	1360	800	14 Bar	500	1655	279	1084	203	103	915	950
OVE - 34000	1/2"	DN80	2040	1200	14 Bar	600	1520	281	931	254	103	762	790
OVE - 45000	1/2"	DN80	2720	1600	14 Bar	600	1671	281	1086	254	103	915	950
OVE - 59500	1/2"	DN100	3570	2100	14 Bar	700	1575	335	953	300	129	762	790
OVE - 78000	1/2"	DN100	4675	2750	14 Bar	700	1726	335	1100	300	129	915	950
OVE - 119000	1/2"	DN150	7140	4200	14 Bar	800	1670	393	983	365	181	762	790
OVE - 170000	1/2"	DN150	10200	6000	14 Bar	800	1925	393	1238	365	181	950	1045
OVE - 227000	1/2"	DN200	13600	8000	14 Bar	850	2020	417	1277	386	233	1016	1045
OVE - 284000	1/2"	DN250	17000	10000	14 Bar	1000	2118	417	1307	407	337	1016	1045
OVE - 340000	1/2"	DN300	20400	12000	14 Bar	1000	2688	497	1847	437	337	1524	1550

CORRECTION FACTORS

Operating pressure (barg)	1	3	5	7	9	11	13	14
Operating pressure PSIG	15	44	73	100	131	160	189	200
Correction Factor	0,5	0,71	0,87	1	1,12	1,22	1,32	1,38

To find the most suitable model with high efficiency, multiply the flow rate from the table with the corresponding correction factor on the left.

Drain Type

Adjustable electronic

External drain

Zero loss drain

Manual

OUR COMPANY MAY CHANGE THE VALUES IN THE CATALOGUE ACCORDING TO THE RESEARCH AND DEVELOPMENT STUDIES.

